

Features

Max. tensile strength 1.330 N, working load 930 N.
Quick opening and closing by a push of the finger.
Easy installation with single hole mounting.

Selection Instructions

1. Select stud assembly, page K-2 or K-3 and receptacle, page K-4.
2. Select retaining washer, page K-2 and retaining hexnut, page K-3, if necessary.
3. Select stud length number from Panel thickness P or Panel distance G using the table below.

Push Button

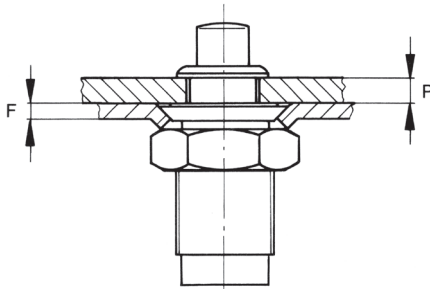

Push Panel

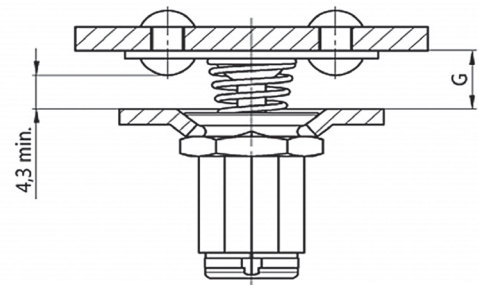

Stud Length Table

Panel Thickness P	Stud Length No.
0,7 - 2,3	1
2,3 - 3,8	3
3,8 - 5,3	5
5,3 - 6,9	7
6,9 - 8,4	9
8,4 - 9,9	11
9,9 - 11,4	13
11,4 - 13,0	15

Other lengths on request.

Stud Length Table

Panel Distance G	Stud Length No.
6,1 - 6,9	8
6,9 - 7,6	9
7,6 - 8,4	10
8,4 - 9,1	11
9,1 - 9,9	12
9,9 - 10,7	13
10,7 - 11,4	14
11,4 - 12,2	15

Other lengths on request.

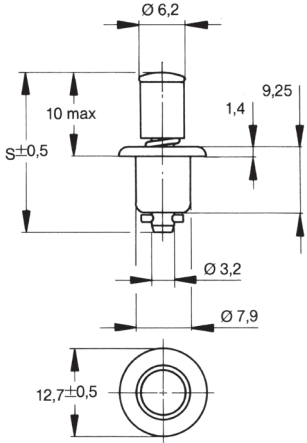
Style	Dimensions	Materials / Finish	°C	Part No.
Push Button 	 <p>S=22,4 + (0,76 x length no.)</p>	Steel / nickel-plated	120	15S1- *-1AD
		Steel / zinc-plated CrVI-free, clear passivation	120	15S1- *-1AJ

* Length no. from Table „Push Button“, see page K-1.

Other lengths and surfaces can be ordered upon request.

Stud Installation Instructions

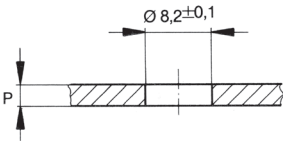
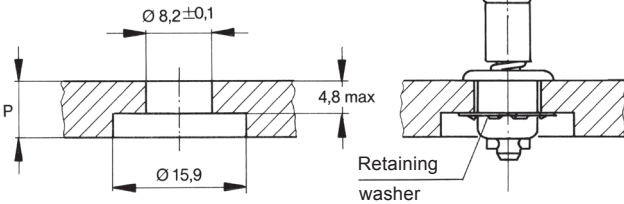
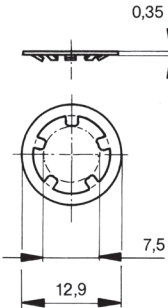
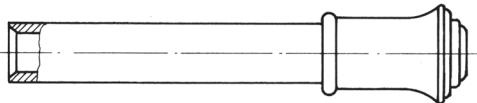
Installation Dimensions	Accessories	Materials / Finish	Part No.
<p>Panel thickness up to 4,8</p>  <p>Panel thickness from 4,8 + up</p> 	<p>Retaining washer</p> 	Stainless steel	15S11-1CJ
	<p>Installation Tool for 15S11-1CJ retaining washer</p>		T107-1

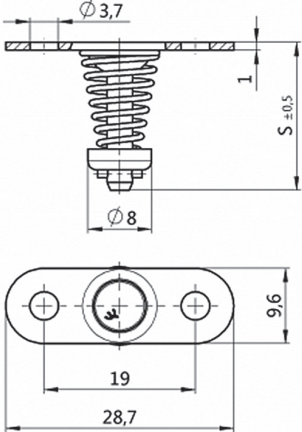
Style	Dimensions	Materials / Finish	°C	Part No.
<p>Push Panel</p> 	 <p>$S=22,4 + (0,76 \times \text{length no.})$</p>	<p>Steel / zinc-plated CrVI-free, clear passivation</p>	120	V15S20- *-1AGV

* Length no. from Table „Push Panel“, see page K-1.

Other lengths and surfaces can be ordered upon request.

Stud Installation Instructions

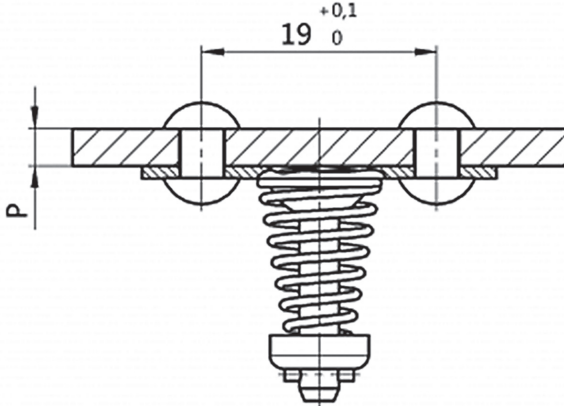
Installation Dimensions
<p>Push Panel Rivet-/ Screw Mounting</p> 

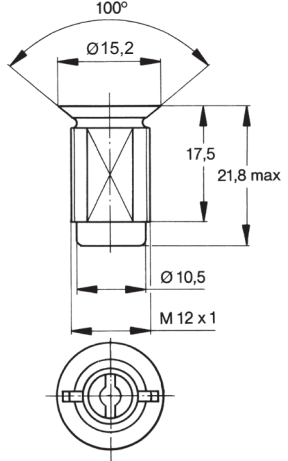
Style	Dimensions	Materials / Finish	°C	Part No.
		Zinc die casting / zinc-plated CrVI-free, clear passivation	120	V15R13-1-1AB

Receptacle Installation Instructions

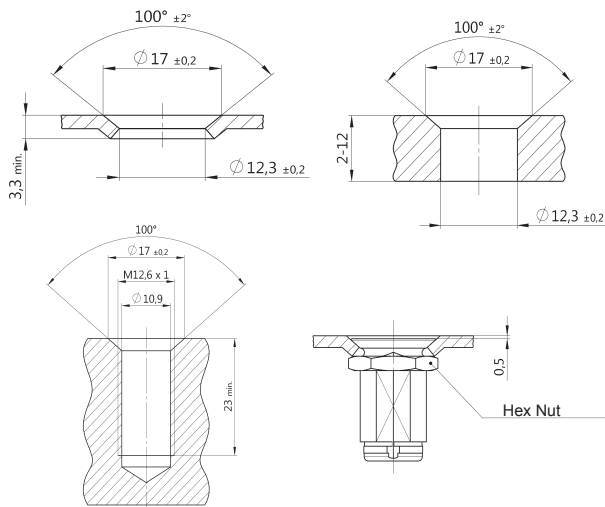
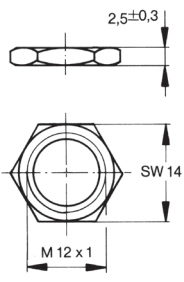
Installation Dimensions	Accessories	Materials / Finish	Part No.
	Hex Nut  Recommended torque for the Hex Nut: 2.3Nm to 3.0Nm	Steel / zinc-plated, CrVI-free, clear passivation	V15R14-1-1AB